

NOTICE

THIS DRAWING IS CONFIDENTIAL AND IS SUPPLIED ON THE EXPRESS CONDITION THAT IT SHALL NOT BE LENT, COPIED OR DISCLOSED TO ANY OTHER PERSON OR USED FOR ANY PURPOSE WITHOUT THE PRIOR WRITTEN CONSENT OF EFI TECHNOLOGY, INC. CA

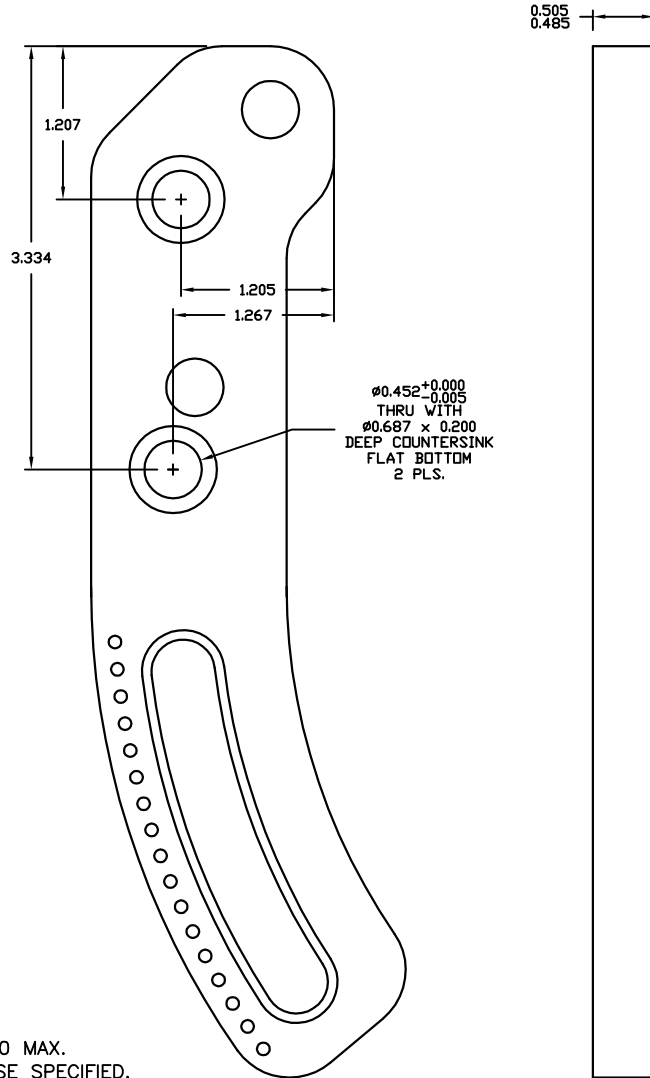

NOTES:

- ALL UNSPECIFIED INTERNAL FILLET RADII TO BE 0.010 MAX.
- MACHINING TOLERANCE $\pm 0.005/.5'$ UNLESS OTHERWISE SPECIFIED.
- ALL HOLES TO BE WITHIN 0.005 OF TRUE POSITION.
- REMOVE ALL SHARP EDGES

REVISIONS

LTR	DESCRIPTION	DATE	APPROVED
	INITIAL RELEASE	06/27/17	

CUSTOMER APPROVAL:			
		BIG BLOCK CHEVY PICKUP BRACKET MOUNT	
CHECKED BY:	DRAWN BY: M.N.	DATE: 06/27/17	
REV:	MAT'L: 6061 T6	DWG #: 99-515	
DO NOT SCALE DRAWING			SHEET NO: 1 OF 1